

## VQ Series Needle Valve

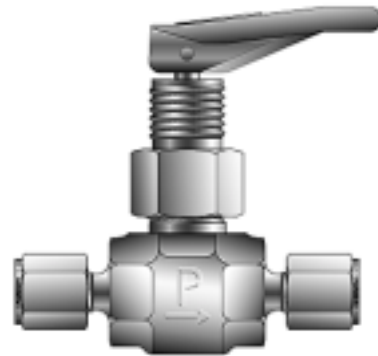

### MAXIMUM WORKING PRESSURE AND TEMPERATURE

Valve Size	Max Pressure and Temperature	Max Temperature and Pressure
V4Q	300 Psig at 70 °F 2.1 MPa at 21 °C	300 Psig at 200 °F 2.1 MPa at 93 °C
V6Q	300 Psig at 70 °F 2.1 MPa at 21 °C	300 Psig at 200 °F 2.1 MPa at 93 °C

Refer to Parker VQ Series Needle Valve Maintenance Instructions MI-101 when Valve disassembly is required. Always consult your authorized Parker representative if questions arise. The arrow on the Valve Body indicates the normal direction of flow.

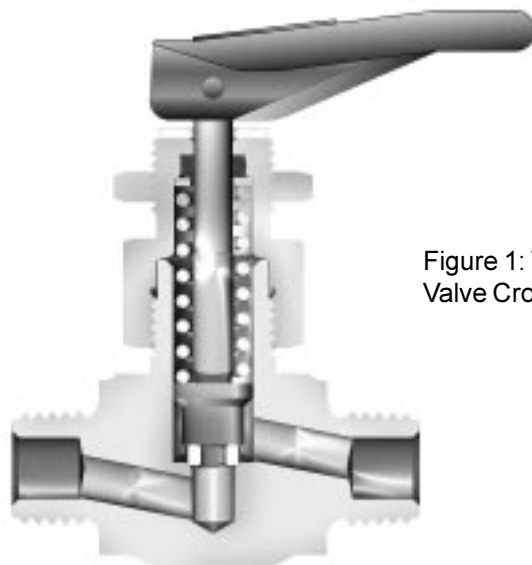

Figure 1: VQ Series Toggle Needle Valve Cross Sectional View

## PANEL MOUNTED VALVES

The panel must have a through-hole of the proper diameter as listed below:

V4Q Valves      33/64 inch (13.1 mm)

V6Q Valves      41/64 inch (16.3 mm)

The maximum panel thickness is 1/4 inch (6.4 mm). When the Valve is to be mounted to a thin panel, a spacer (or washer) may be necessary to permit full Panel Nut engagement on the Valve. It is not necessary to disassemble the Valve for panel mounting.

1. Actuate the Handle up to the “open” position, such that it is parallel with the Valve Stem.
2. Insert the Valve through the hole in the panel, and assemble the Panel Nut onto the Cap until the Panel Nut is finger-tight.
3. Tighten the Panel Nut with the correct sized wrench as specified below:  
V4Q Valves      11/16 inch hex wrench  
V6Q Valves      13/16 inch hex wrench
4. Actuate the Handle back to the “closed” position, such that it is at right-angles with respect to the Valve Stem.

## USE OF THE (OPTIONAL) HANDLE POSITIONER

Assemble the positioner in the same manner as the Panel Nut. The positioner intentionally fits tightly on the valve and should be wrench tightened with the proper sized wrench as noted below:

V4Q Valves      5/8 inch hex wrench

V6Q Valves      3/4 inch hex wrench

When using the handle positioner and a panel mounting valve, the maximum panel thickness is 1/8 inch (3.2 mm). Whenever assembling the handle positioner, make certain it is screwed onto the valve far enough to allow the valve to fully close. This is evident by a visible gap between the handle and the slot in the positioner, and the lever handle will feel loose.

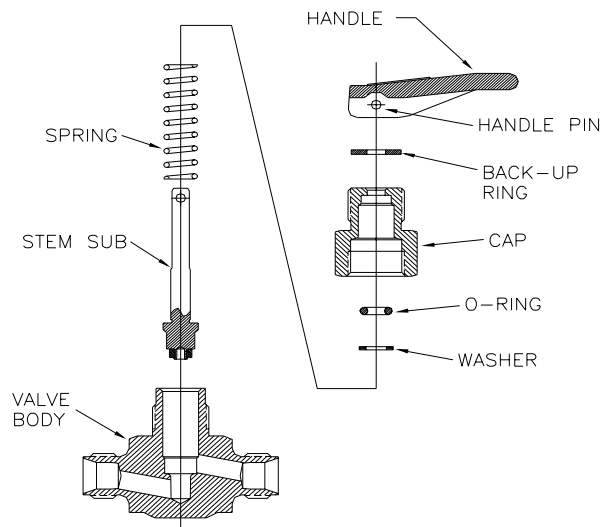

Figure 2: VQ Series Toggle Needle Valve Exploded View

## VALVE CONNECTOR MAKE-UP INSTRUCTIONS

### MALE AND FEMALE PIPE PORTS

Wrench flats are provided on the Valve Body. It is recommended a smooth-jawed wrench or vise be used to grip the Valve Body.

1. On the male threaded part of the connection, apply a high quality pipe joint compound or PTFE tape made for this purpose. When PTFE tape is used, it is recommended two full turns of tape be applied. PTFE tape should not be overhanging or covering the first thread
2. Engage the Valve and the other component part together, until hand-tight.
3. With a proper wrench, holding both the Valve and the component part, continue to tighten to achieve a leak-tight joint.

### ULTRASEAL CONNECTIONS

1. Insert the proper O-Ring into the UltraSeal fitting's O-Ring groove. Position the UltraSeal gland sealing face against the O-Ring, and then advance the Nut to a finger-tight position.
2. A positive seal is obtained by advancing the Nut no less than 1/4 turn from the finger-tight position. Proper UltraSeal make-up is achieved when a sharp rise in required application torque occurs, which indicates proper seal face contact and O-Ring seal compression into the UltraSeal groove.

### VACUSEAL CONNECTIONS

1. A positive seal is obtained by advancing the Nut 1/8 turn from the finger-tight position.
2. A new gasket should be installed upon each fitting re-make to insure system pressure integrity.

### TUBE FITTING CONNECTIONS

1. Insert the tube into the Valve port until the tube bottoms out in the Valve Body. Care should be exercised to insure the tube is properly aligned with the Valve Body and port.
2. Normal make-up for US Customary port sizes 1 thru 3 (1/16 thru 3/16 inch) and SI port sizes 2 thru 4 (2 thru 4 mm) is 3/4 turn from finger tight. Normal make-up for US Customary port sizes 4 thru 16 (1/4 thru 1 inch) and SI port sizes 5 thru 25 (5 thru 25 mm) is 1 1/4 turn from finger tight. For larger port sizes consult Parker Ferrule Presetting Tool Instructions.

**PLEASE FOLLOW THE ABOVE DIRECTIONS FOR COUNTING THE NUMBER OF TURNS FOR PROPER FITTING MAKE-UP. DO NOT MAKE-UP TUBE FITTINGS BY TORQUE OR "FEEL". VARIABLES SUCH AS TUBING AND FITTING TOLERANCES, TUBE WALL THICKNESS, AND THE LUBRICITY OF NUT LUBRICANTS CAN RESULT IN AN IMPROPERLY ASSEMBLED TUBE FITTING CONNECTION.**

**A** -Two ferrule A-LOK®  
compression port



**Z** -Single ferrule CPI™  
compression port



**F** -ANSI/ASME B1.20.1  
Internal pipe threads



**V** -VacuSeal face  
seal port



**Q** -UltraSeal face  
seal port



**M** -ANSI/ASME B1.20.1  
External pipe threads



---

## WARNING

**FAILURE OR IMPROPER SELECTION OR IMPROPER USE OF THE PRODUCTS AND/OR SYSTEMS DESCRIBED HEREIN OR RELATED ITEMS CAN CAUSE DEATH, PERSONAL INJURY AND PROPERTY DAMAGE.**

This document and other information from Parker Hannifin Corporation, its subsidiaries and authorized distributors provide product and/or system options for further investigation by users having technical expertise. It is important that you analyze all aspects of your application and review the information concerning the product or system in the current product catalog. Due to the variety of operating conditions and applications for these products or systems, the user, through its own analysis and testing, is solely responsible for making the final selection of the products and systems and assuring that all performance, safety and warning requirements of the application are met.

The products described herein, including without limitation, product features, specifications, designs, availability and pricing, are subject to change by Parker Hannifin Corporation and its subsidiaries at any time without notice.

**ALL PARKER VALVES MUST PASS A RIGID OPERATIONAL AND LEAKAGE TEST BEFORE LEAVING THE FACTORY. IT IS RECOMMENDED AFTER ANY REASSEMBLY, THE VALVE SHOULD BE TESTED BY THE USER FOR OPERATION AND LEAKAGE. IF THESE INSTRUCTIONS ARE NOT FULLY COMPLIED WITH, THE REPAIRED PRODUCT MAY FAIL AND CAUSE DAMAGE TO PROPERTY OR INJURY TO PERSONS. PARKER HANNIFIN CANNOT ASSUME RESPONSIBILITY FOR PERFORMANCE OF A CUSTOMER SERVICED VALVE.**

